

WTA

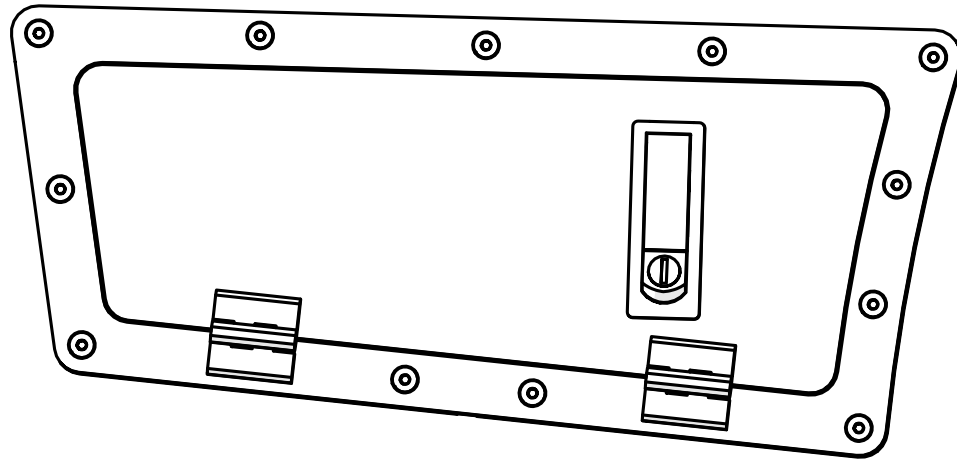

Installation Guide



SPRINTER REAR PANEL STORAGE LOCKERS

It is crucial to ensure that all WTA products are assembled and securely attached to your vehicle. Failure to do so may result in automobile accidents, posing a significant risk of bodily injury or even death to yourself and others. As the owner, it is your responsibility to properly assemble and secure WTA products, diligently inspecting the mounting points and attachments before use, and regularly checking for any signs of wear or damage.

To guarantee optimal safety, we strongly advise engaging the services of a professional installer for the installation of any aftermarket accessories to your vehicle. If you lack mechanical experience or are unfamiliar with the installation procedures, it is imperative to have the product installed by a qualified professional or individuals who possess the necessary expertise. Remember, the responsibility lies with you, and it must be taken seriously to ensure the safety of all individuals involved.

PACKAGE CONTENTS

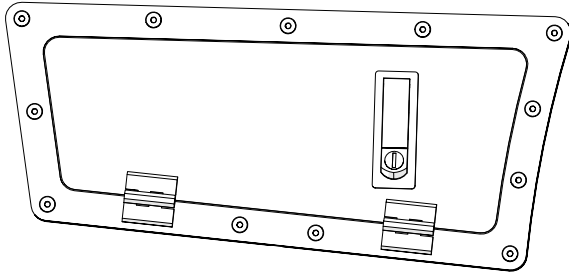

**PASSENGER SIDE
DOOR FRAME ASSEMBLY**

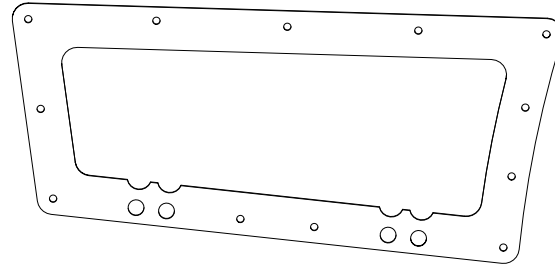

**DOOR FRAME GASKET
QTY: 2**

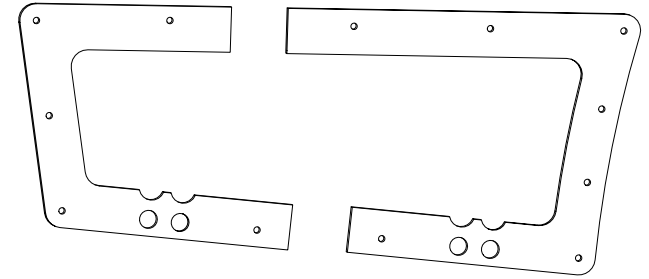

**BACKING PLATE 1
QTY: 2**

**BACKING PLATE 2
QTY: 2**

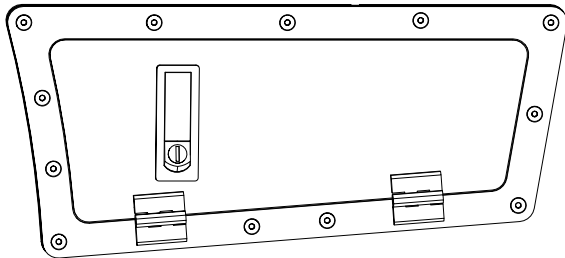

**DRIVER SIDE
DOOR FRAME ASSEMBLY**

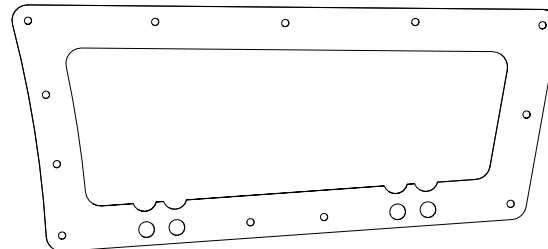

**DRILL & CUT STENCIL
QTY: 1**

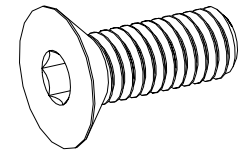

**COUNTERSUNK SCREW
QTY:24**

INSTALL

STEP | 01 LAYOUT AND INSTALL PREP

- 1.1 Clean the rear panels of any dirt and debris.
- 1.2 Use tape to line up the stencil to the body panel. Visualize how the locker will fit on the van.
- 1.3 Mark all holes with a sharpie,
- 1.4 Cutting path: Trace around the inside of the gasket to mark the cutting path, Ensure the gasket is flat against the van
- 1.5 You should be left with making as shown in pic3 after removing the tape and gasket

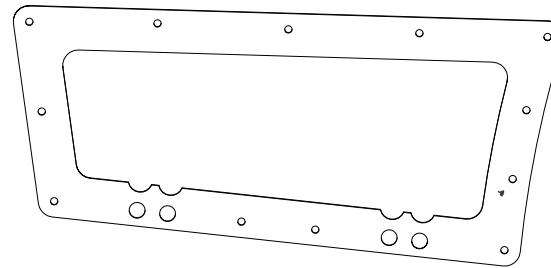

DRILL & CUT STENCIL

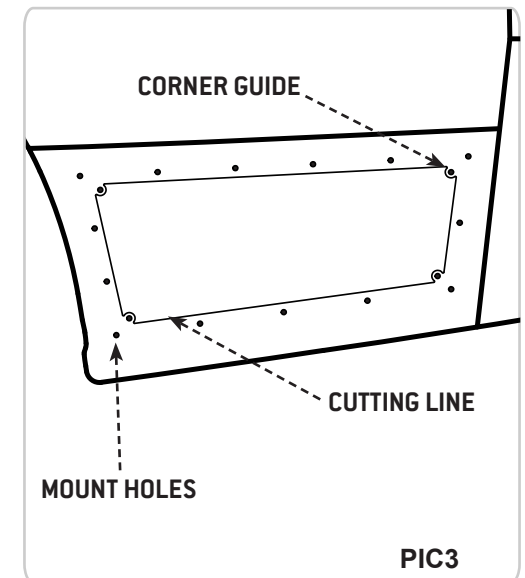
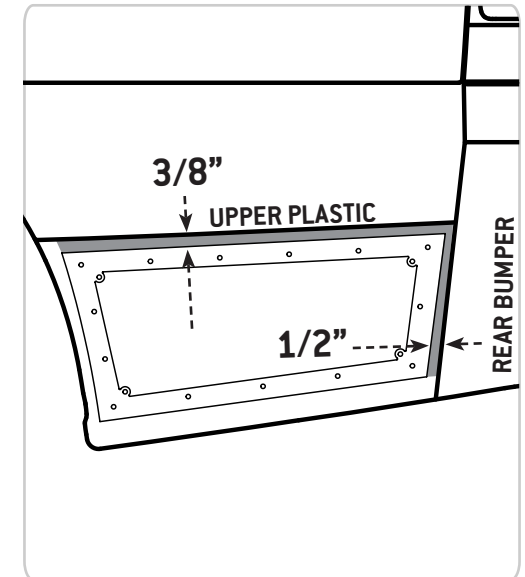

STEP | 02 DRILING HOLES AND CUTTING PANELS

2.1 Drill out holes using a M8 Drill Bit

2.2 Drill out corners with a stepped drill bit. Try to go just past (outside) the line you drew. This will help when cutting out the panel

2.3 Use a body saw or angle grinder with a metal cutting wheel to cut the panel around the mark lines.

2.4 Debur the holes and clean up shavings on the inside and outside edges of the compartment

2.5 Paint raw edges of drill holes and cut lines with rust preventative paint.

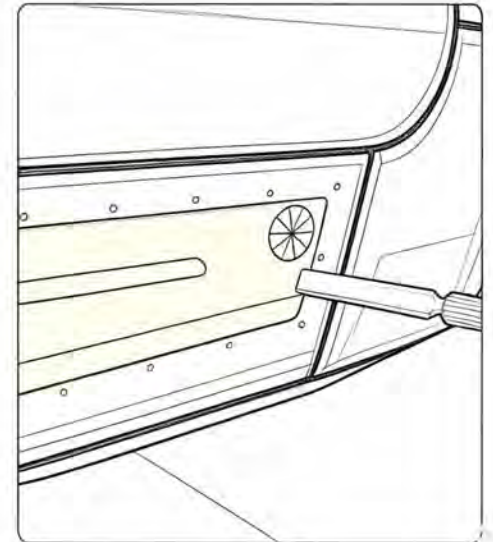
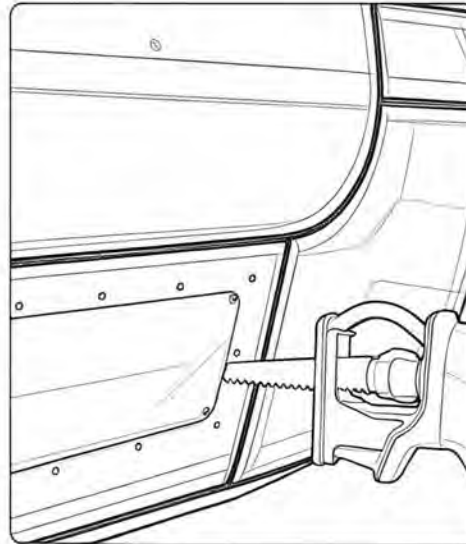
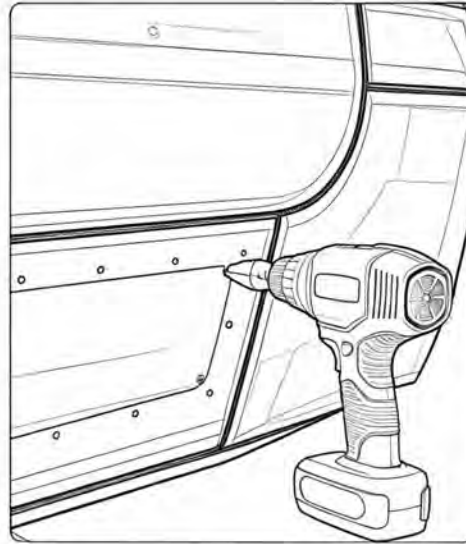

STEP | 03 LOCKER ASSEMBLY

3.1 Align the face plate ,gasket,and backer plates with holes you drilled in the van

3.2 Secure the face panel to the Van with M6 flat head screw sandwiching the gasket and body between the face and backing plate (make sure to install all screws before tightening them down)

3.2 You may use Loctite on the screws, once all screws are in one by one replace them with screws with locktite, you may need to apply pressure to flex the assembly into place when tightening screws

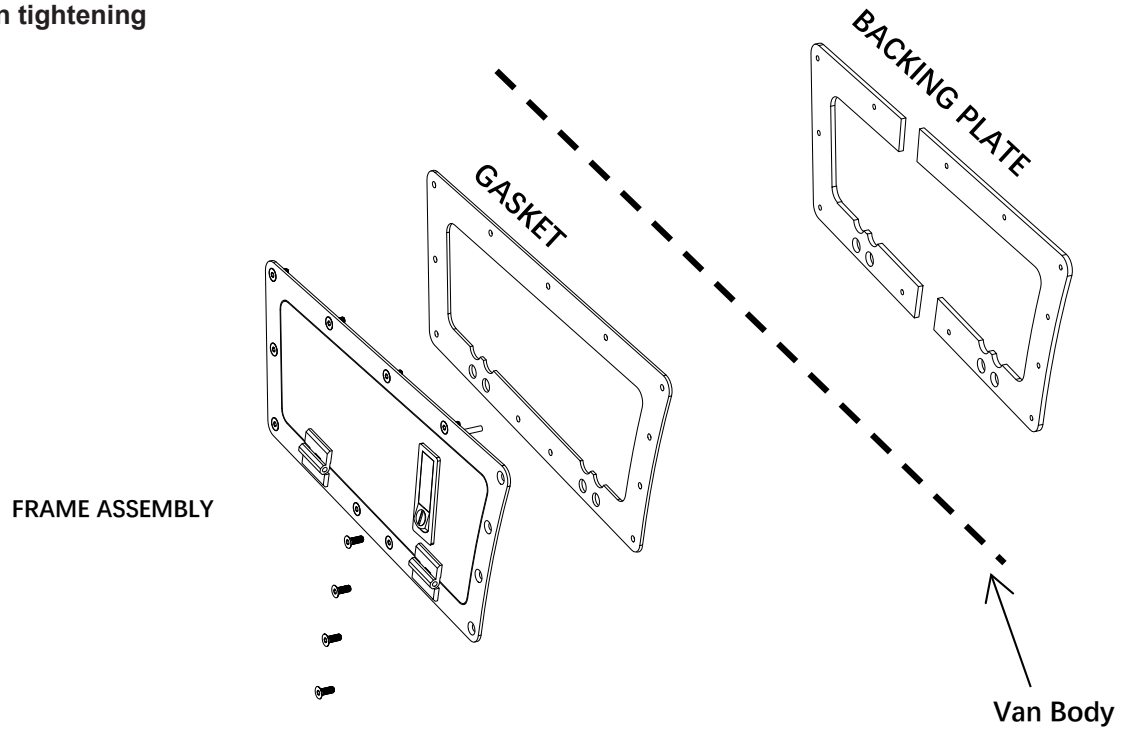

GET THERE WITH WHITE TOP ADVENTURES



thanks!



info@whitetopadventures.com