

# WTA



## Installation Guide



### **PROMASTER Roof Rack PM159HR**

It is crucial to ensure that all WTA products are assembled and securely attached to your vehicle. Failure to do so may result in automobile accidents, posing a significant risk of bodily injury or even death to yourself and others. As the owner, it is your responsibility to properly assemble and secure WTA products, diligently inspecting the mounting points and attachments before use, and regularly checking for any signs of wear or damage.

To guarantee optimal safety, we strongly advise engaging the services of a professional installer for the installation of any aftermarket accessories to your vehicle. If you lack mechanical experience or are unfamiliar with the installation procedures, it is imperative to have the product installed by a qualified professional or individuals who possess the necessary expertise. Remember, the responsibility lies with you, and it must be taken seriously to ensure the safety of all individuals involved.

# PACKAGE CONTENTS

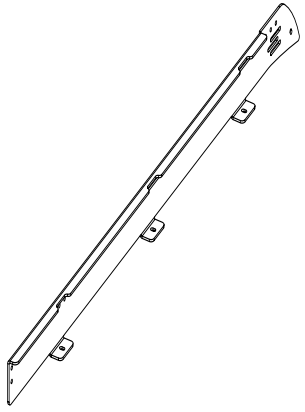

DRIVER FRONT  
RAIL QTY-1

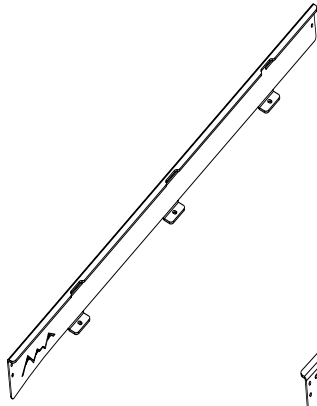

DRIVER REAR RAIL  
QTY-1

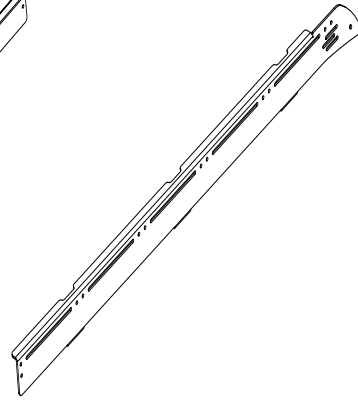

PASSENGER FRONT RAIL  
QTY-1

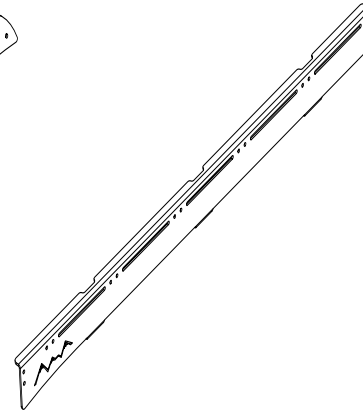

PASSENGER REAR RAIL  
QTY-1

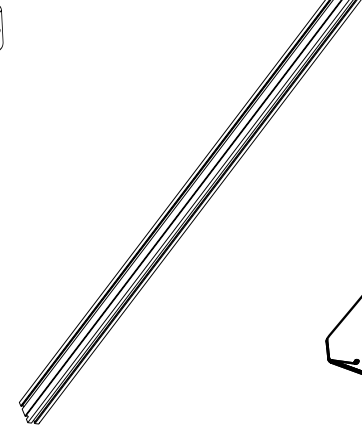

CROSSBAR  
QTY-6

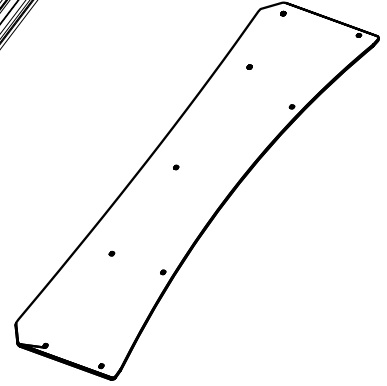

FRONT FAIRING  
QTY-1

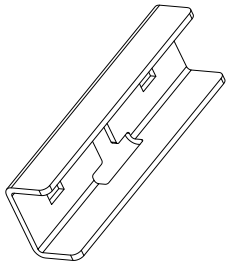

ANCHOR  
BRACKET A  
QTY-12

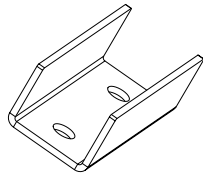

ANCHOR  
BRACKET B  
QTY-12

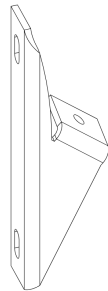

FRONT BRACKET 1  
QTY-1

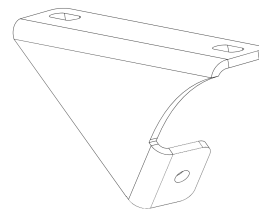

FRONT BRACKET 2  
QTY-1

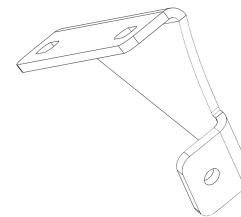

FRONT BRACKET 3  
QTY-1

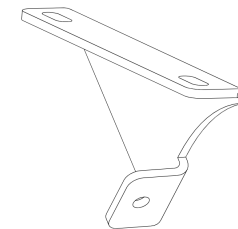

FRONT BRACKET 4  
QTY-1

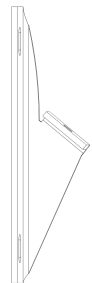

FRONT BRACKET 5  
QTY-1

# HARDWARE PACK

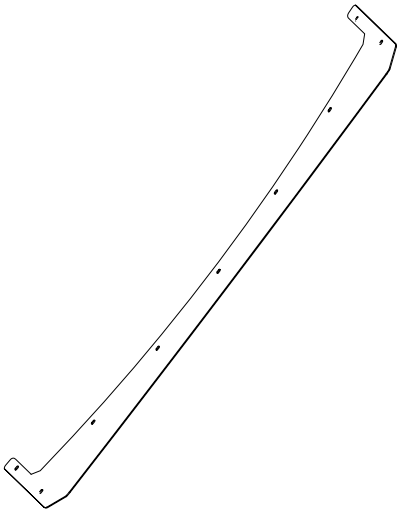

LIGHT BAR FAIRING  
QTY-1

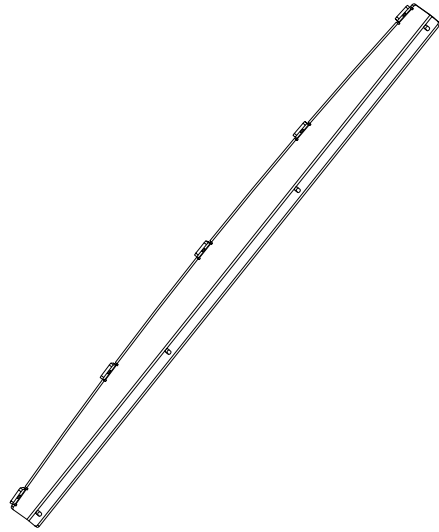

LIGHT BAR FAIRING SUPPORT  
QTY-1

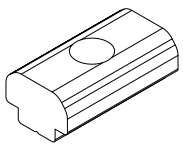

M6 T BLOCK  
QTY-6

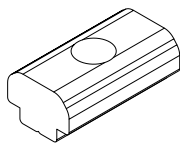

M8 T BLOCK  
QTY-4

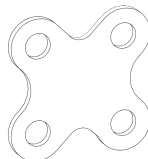

X PLATE  
QTY-2

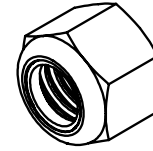

M8 NYLON LOCK NUT  
QTY-32

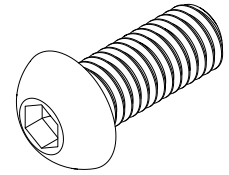

M6-18 BUTTON HEAD SCREW  
QTY-10

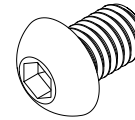

M6-12 BUTTON HEAD SCREW  
QTY-6

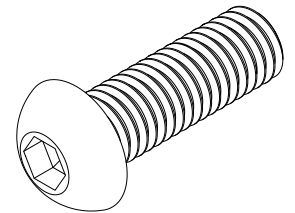

M8-25 BUTTON HEAD SCREW  
QTY-32

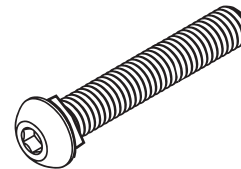

M8-45 CARRIAGE BOLT  
QTY:24

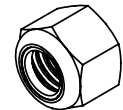

M6 NYLON LOCK NUT  
QTY-10

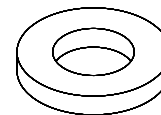

M6 FLAT WASHER  
QTY-26

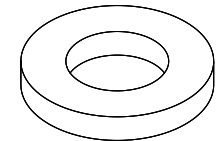

M8 FLAT WASHER  
QTY-56

# INSTALL

## STEP 01 ANCHOR BRACKET A

1.1 Install the **CARRIAGE BOLT** up through the **ANCHOR BRACKET A** first.

1.2 Slide the **ANCHOR BRACKET A** with the **CARRIAGE BOLT**'s on to the T-NUT on the roof of your van. place the **ANCHOR BRACKET B** onto the top of **ANCHOR BRACKET A**.

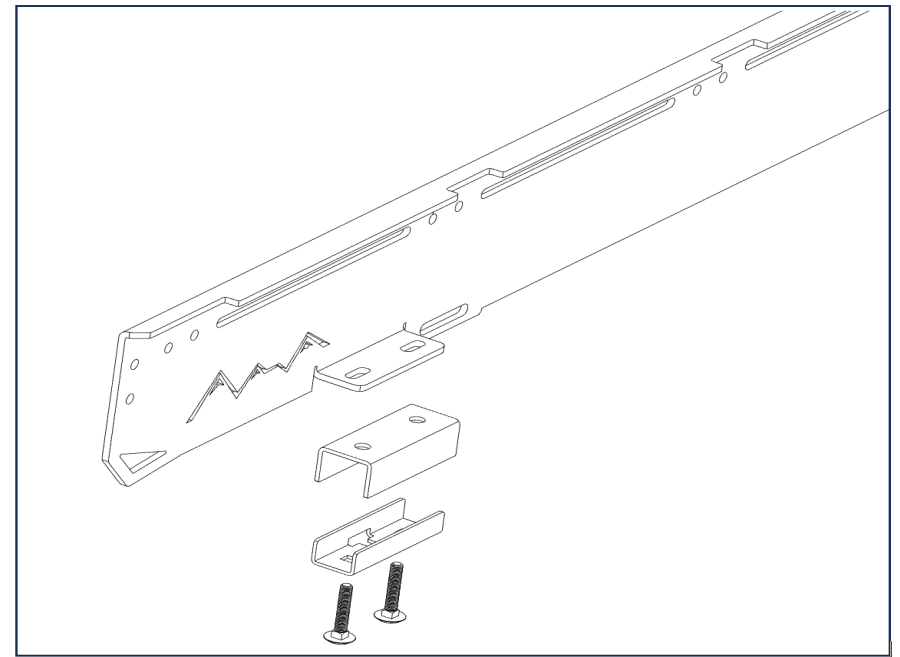
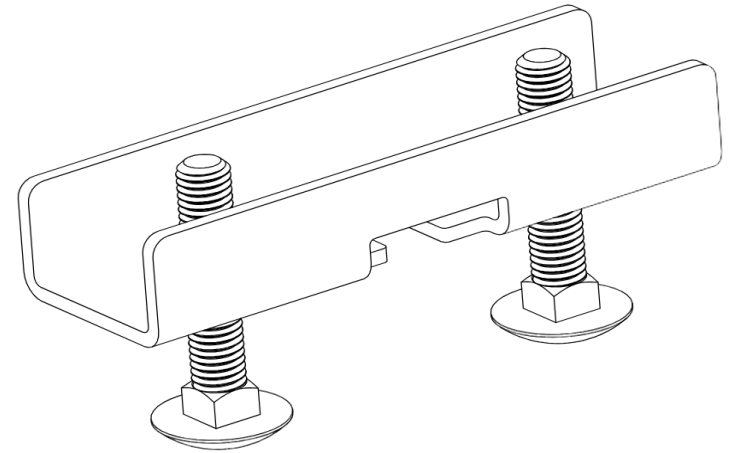

## STEP 02 INSTALL THE RAILS

2.1 Line up the slot holes on the roof rails with the **CARRIAGE BOLT's**, using the M8 nylon lock nut and M8 washer finger tighten, you want to allow the rail to move.

2.2 Repeat the process on all four rails.

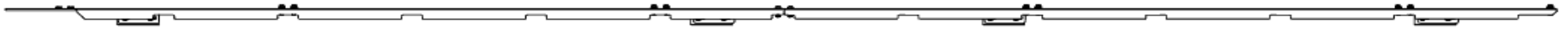
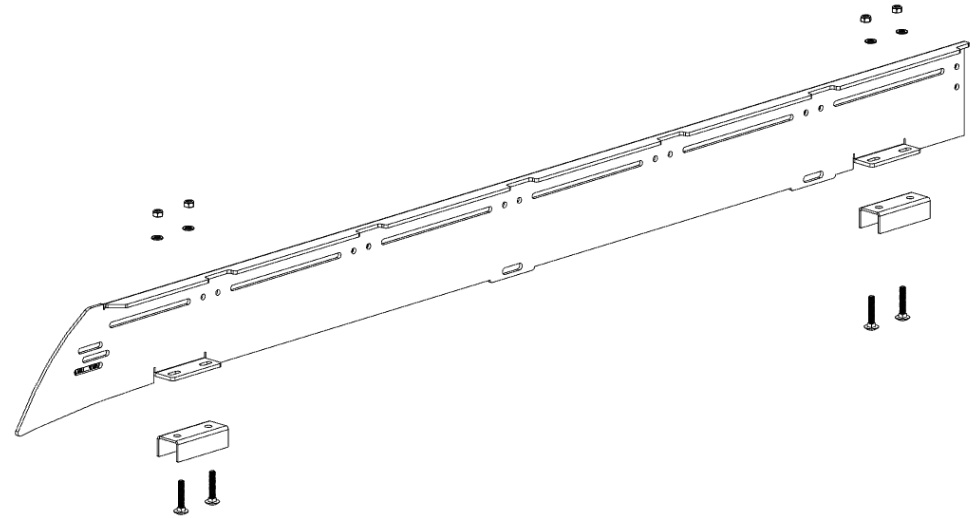

## STEP 03 CROSSBAR & X PLATE

3.1 Align the front side rails and the rear side rails on both sides. Using (4x on each side) **M8-25 button head screw**, (8x) **M8 flat washer** & (4x) **M8 nylon lock nut** to bridge the **X PLATE** between the front and rear side rails.

3.2 Place the crossbars in your desired locations, loosely bolting the **M8x25mm button head screw** & **M8 flat washer** in place **NOTE:** at this point the only things completely tightened down are the **X PLATE's**

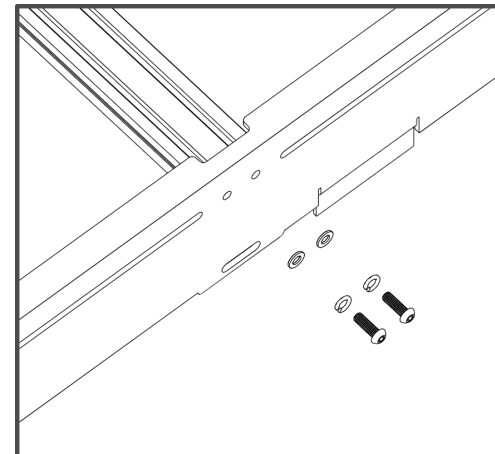
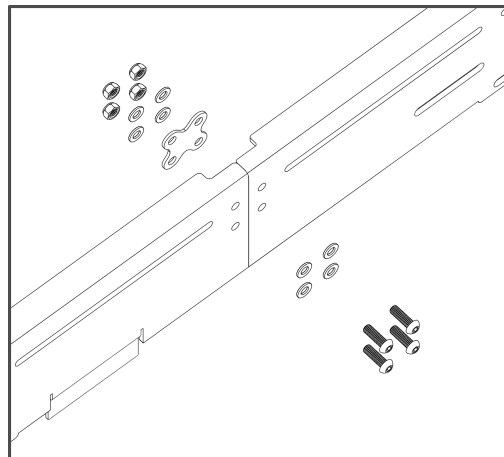
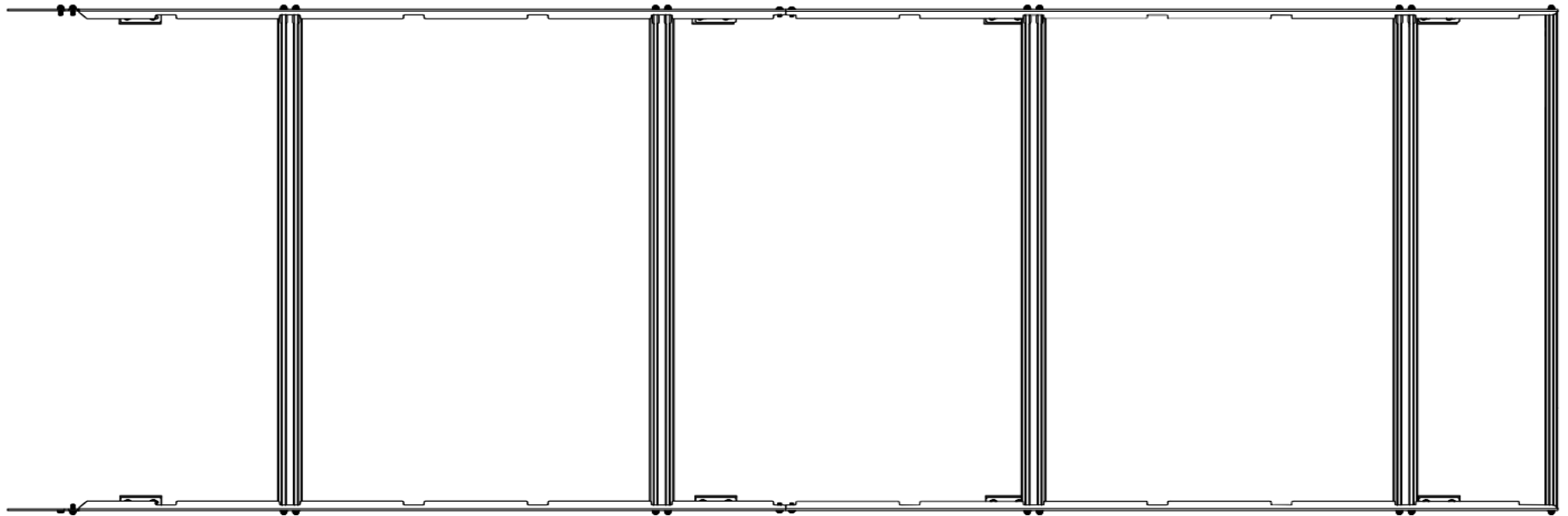

## STEP 04 INSTALL FRONT FAIRING PREP (if installing a light bar skip to step 6)

4.1 Place the **FRONT BRACKET 1-5** in right direction, using the **M6\*12 button head screw**, **M6 flat washer** and **M6 Nylon Lock nut** to fix the the **Front Fairing** to the **FRONT BRACKET's**. **NOTE:** look at the image below to help illustrate bracket location, 1 & 5 are mirrored and 2 & 4 are mirrored parts.

4.2 Install the **T-block** onto the **FRONT BRACKET** with **M6\*12 button head screw** & **M6 flat washer's**. Slide the **cross bar** to the **T-block**, once the **Front Fairing** is centered on the **cross bar** please tighten all screws.

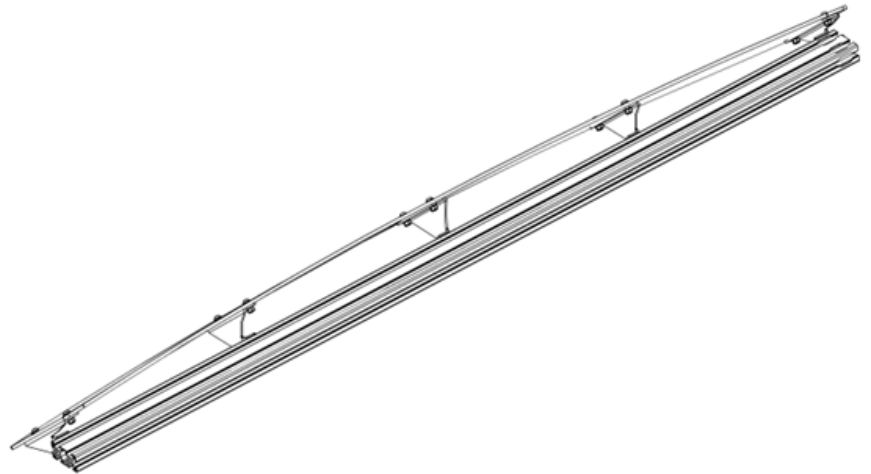
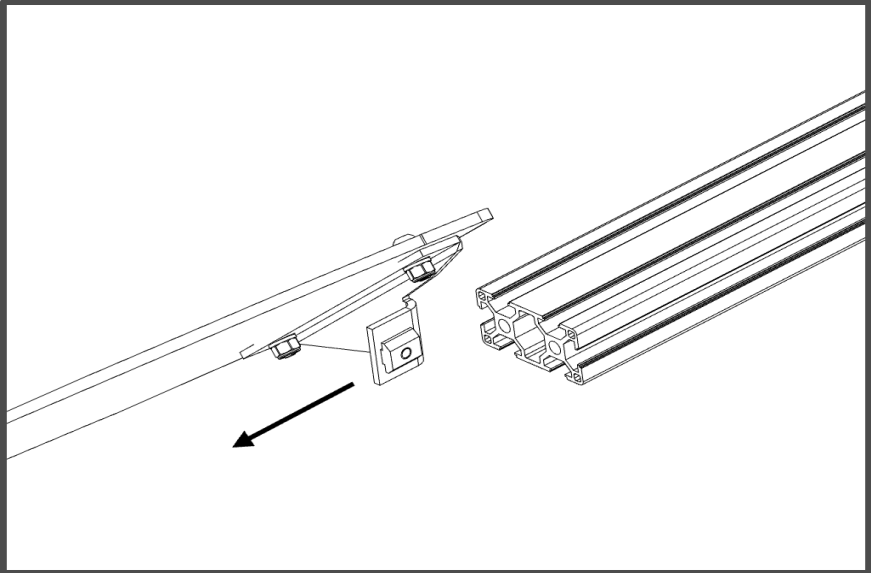
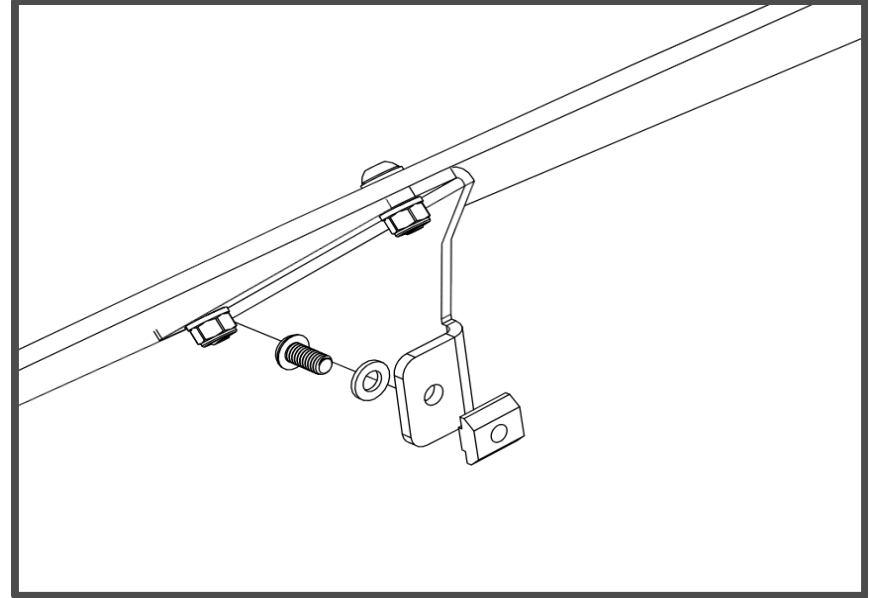
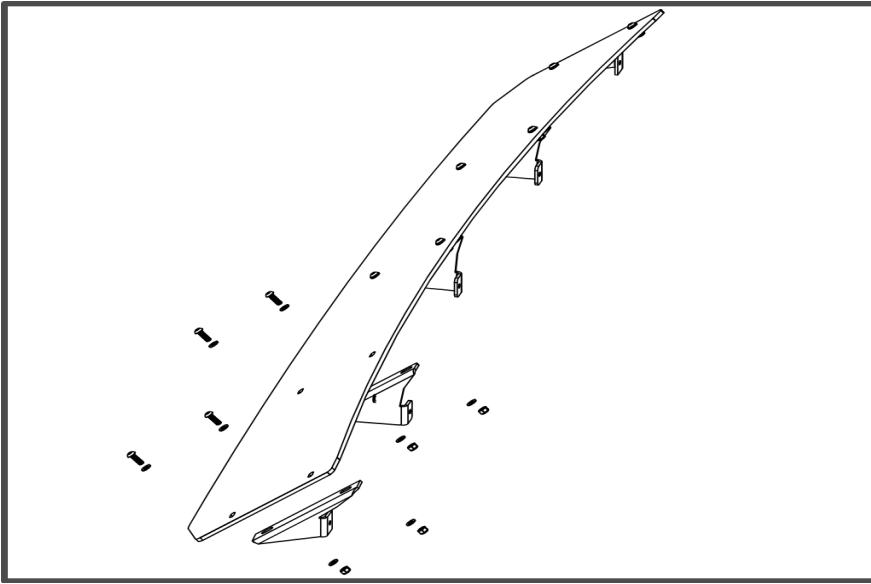

## STEP 05 INSTALL FRONT FAIRING

5.1 Place the **FRONT FAIRING ASSEMBLY** in desired location, using the **M8x25mm button head screws** and **M8 flat washers** assemble and align the front fairing, once both sides are aligned you may tighten down fully.

5.2 Now check alignment and tighten all bolts and nuts starting with the crossbars and then check alignment. Finish with tightening down the anchor brackets.

\*if installing a light bar skip to Step 7

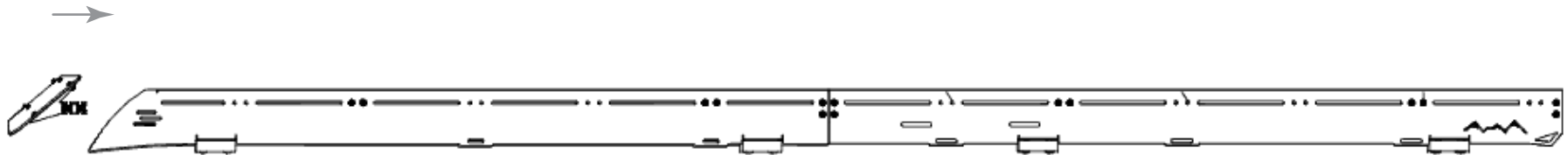
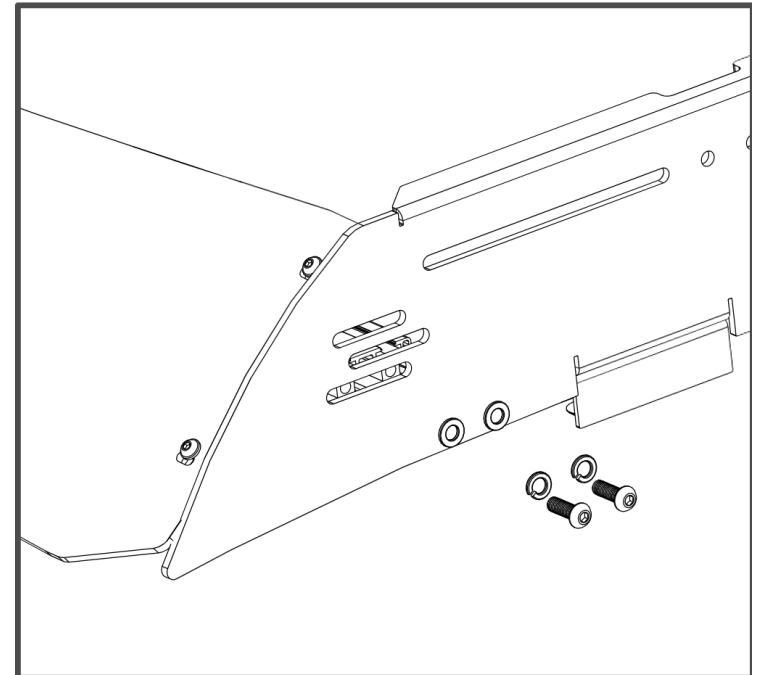
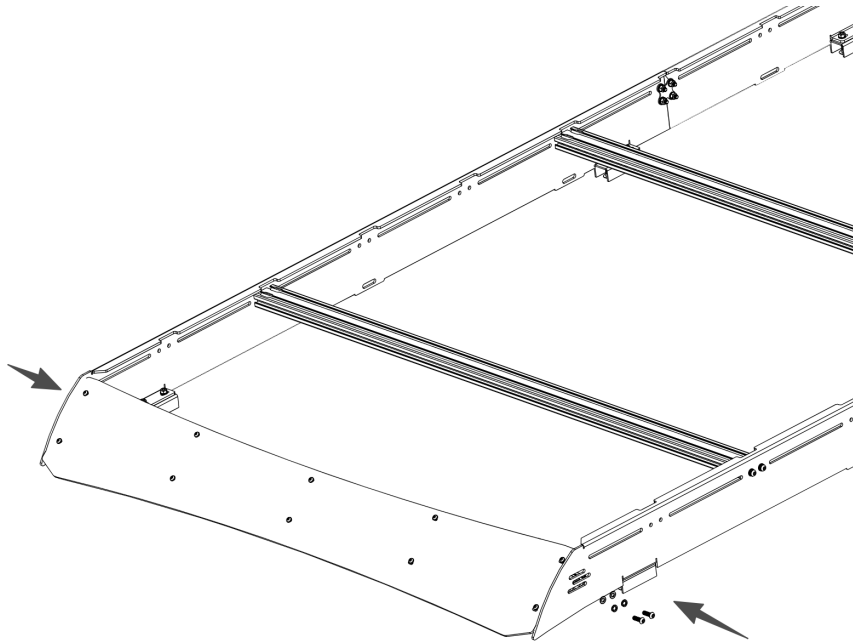

## STEP 06 STANDARD FAIRING OR FAIRING FOR LIGHT BAR

**6.1** Install the light bar fairing on the fairing support with (5x) **M6x18mm BUTTON HEAD SCREW**, **M6 FLAT WASHER** and **M6 NUTS**. \*TIP, Install the hardware loosely through the fairing and slide the cross bar to attach the two. Once centered, tighten down the **M6-18mm BUTTON HEADS** to lock the fairing to the support. Followed by the **M6-12mm BUTTON HEAD SCREWS** connecting the fairing support to cross bar.

**6.2** attache (2x) **M8-12mm BUTTON HEAD SCREWS** with **M8 WASHERS** though **FAIRING BRACKET #1 & #5** Place the fairing brackets numbers 1 and 5 between the cross bar and fairing. Utilize (4x) **M8-25 BUTTON HEAD SCREWS**, (8x) **M8 WASHERS** and (4x) **NYLON LOCK NUTS** to lock the fairing to the brackets then tighten the M8-12mm buttons heads to lock the fairing brackets to the cross bar.

Return to step 5

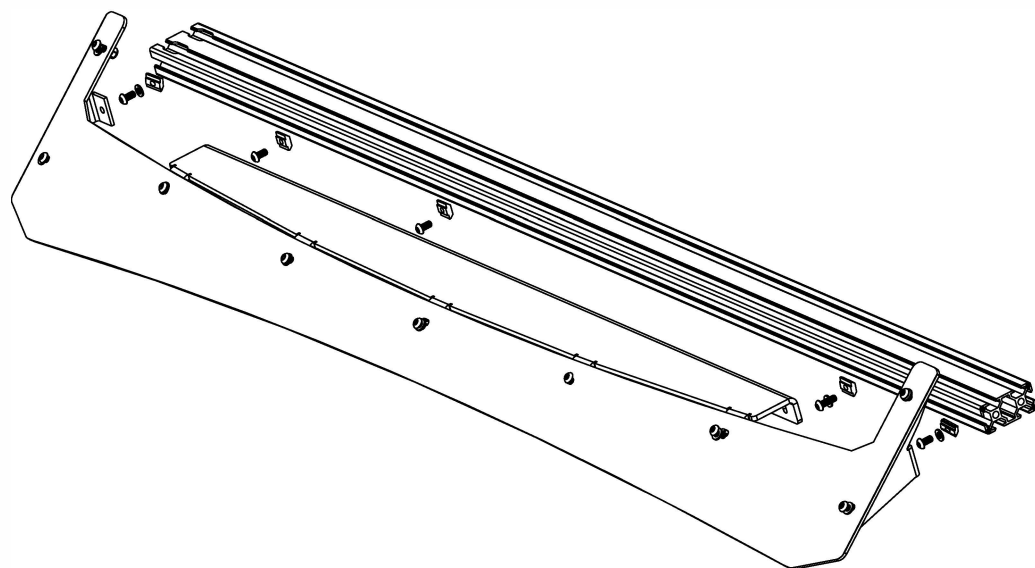
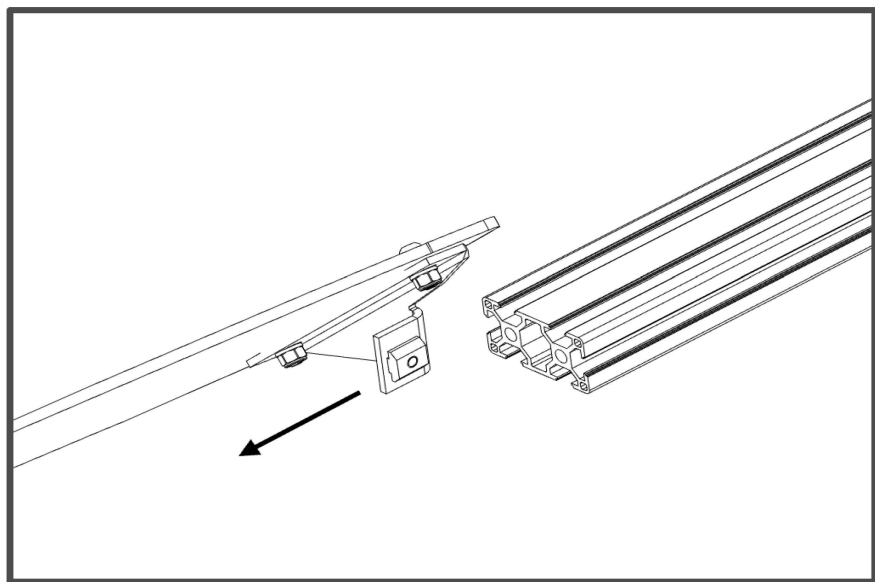
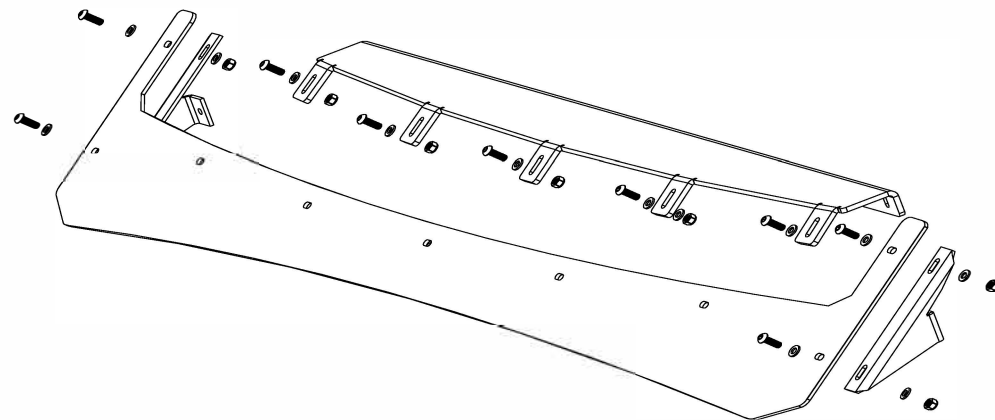

## STEP 07 LIGHT BAR INSTALLATION

7.1 Install the light bar onto the crossbar using M6 or M8 bolts that match the height of your light bar brackets, we provide T-NUT's to be used in the crossbar for this application.

7.2 Please reference your light bar manufacturer for recommended hardware and mounting requirements. We provide a universal rail for almost any width light bar or series of single pods to be mounted.

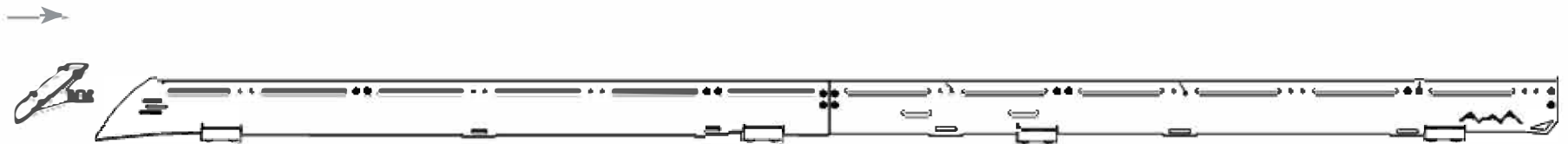
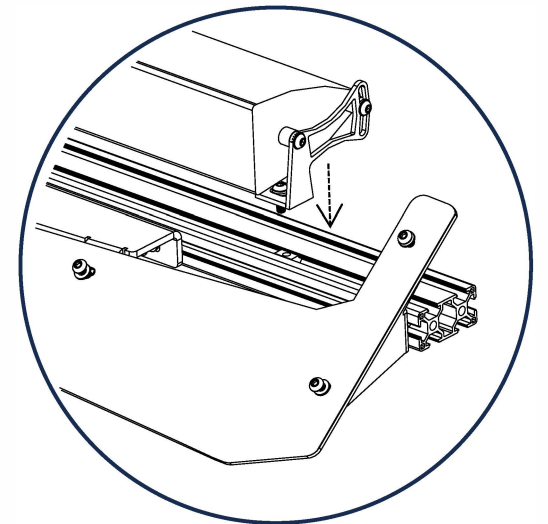
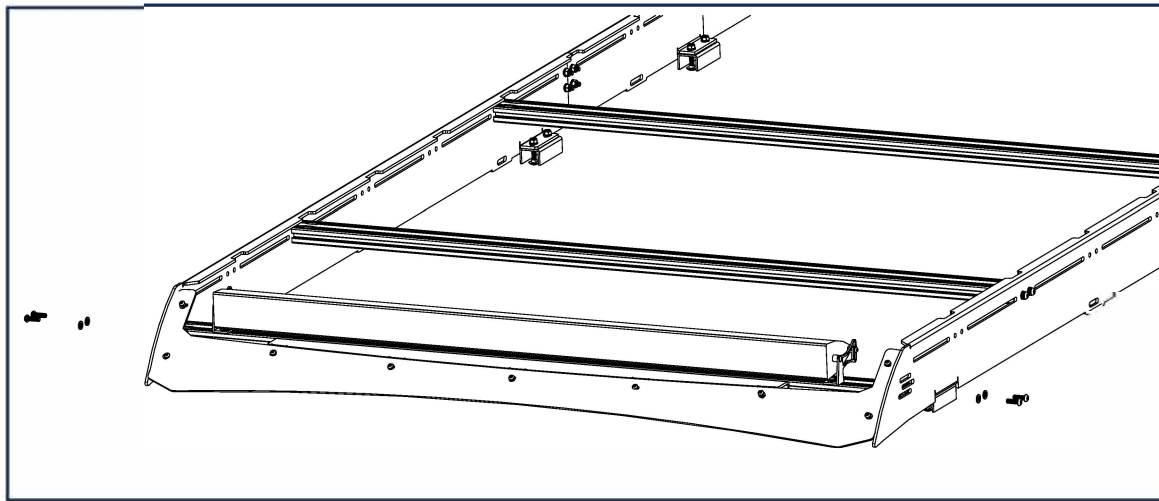

# GET THERE WITH WHITE TOP ADVENTURES



thanks!



[info@whitetopadventures.com](mailto:info@whitetopadventures.com)