

WTA

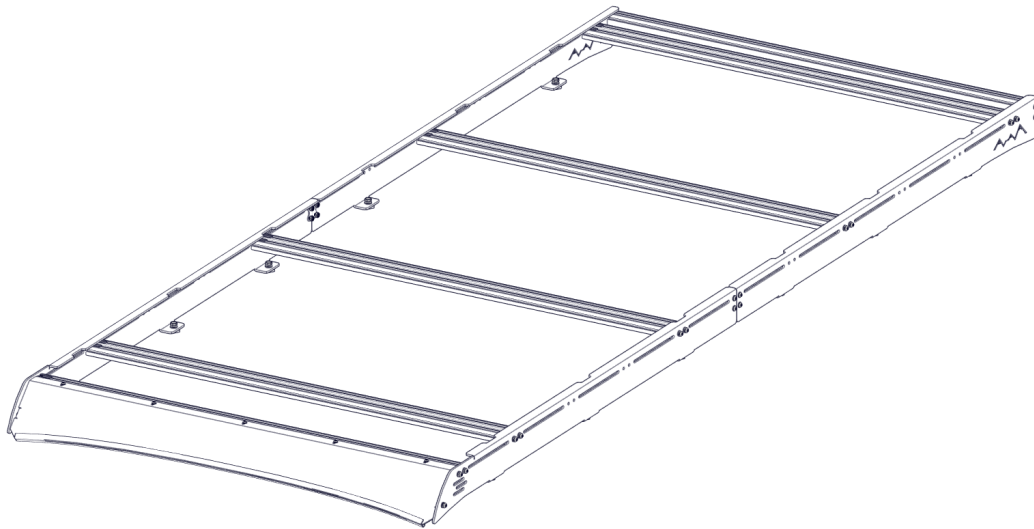

Installation Guide



Sprinter 144 High Roof Stealth Roof Rack

It is crucial to ensure that all WTA products are assembled and securely attached to your vehicle. Failure to do so may result in automobile accidents, posing a significant risk of bodily injury or even death to yourself and others. As the owner, it is your responsibility to properly assemble and secure WTA products, diligently inspecting the mounting points and attachments before use, and regularly checking for any signs of wear or damage.

To guarantee optimal safety, we strongly advise engaging the services of a professional installer for the installation of any aftermarket accessories to your vehicle. If you lack mechanical experience or are unfamiliar with the installation procedures, it is imperative to have the product installed by a qualified professional or individuals who possess the necessary expertise. Remember, the responsibility lies with you, and it must be taken seriously to ensure the safety of all individuals involved.

PACKAGE CONTENTS

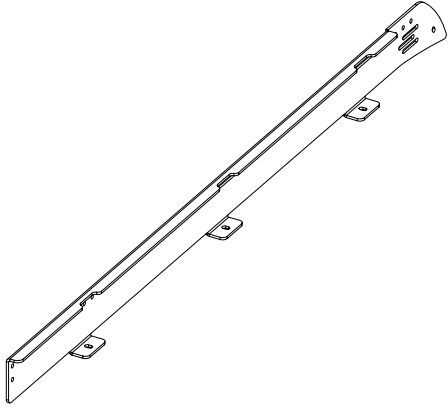

DRIVER FRONT RAIL
QTY-1

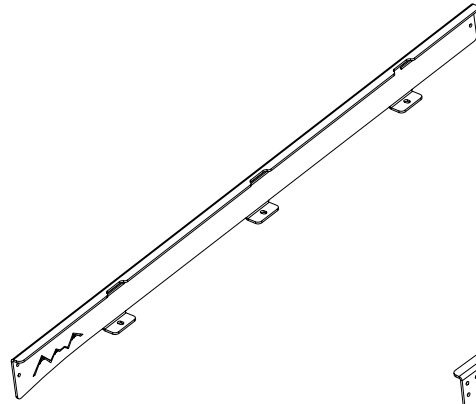

DRIVER REAR RAIL
QTY-1

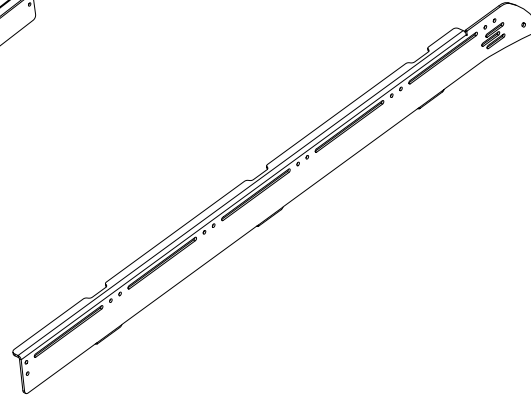

PASSENGER FRONT RAIL
QTY-1

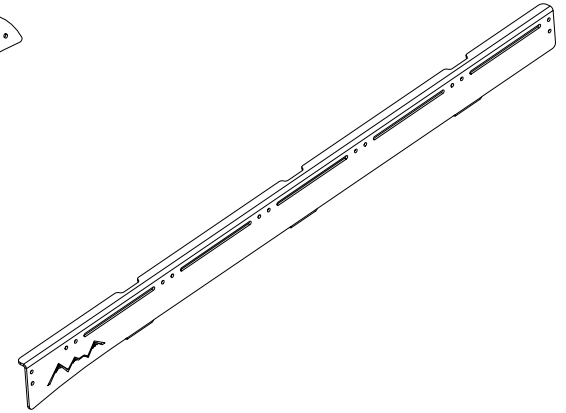

PASSENGER REAR RAIL
QTY-1

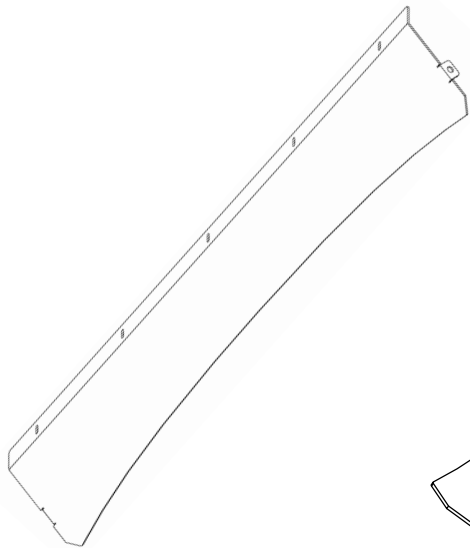

STANDARD FAIRING
QTY-1

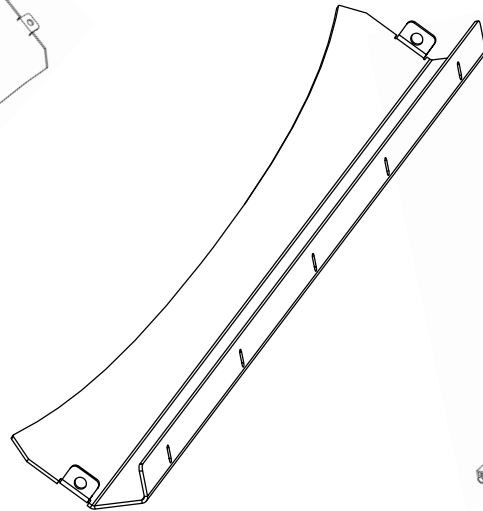

FAIRING FOR LIGHT BAR
QTY-1



RUBER GUARD
QTY-1

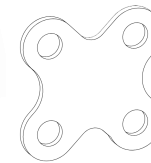

JOINT PLATE
QTY-2



CROSSBAR
QTY-6

HARDWARE PACK

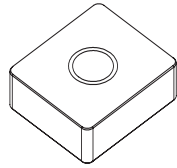

RAIL NUT
QTY-12

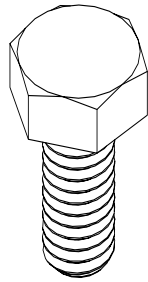

M10-22 HEXAGON
HEAD SCREW QTY-12

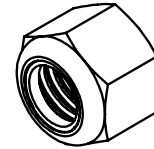

M8-20 NYLON LOCK NUT
QTY-8

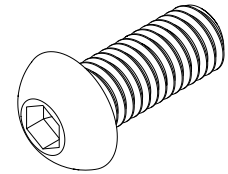

M8-20 BUTTON HEAD SCREW
QTY-8

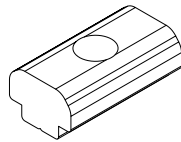

T BLOCK
QTY-6

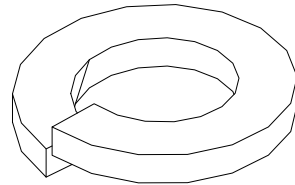

M10 SPRING LOCK
WASHER QTY-12

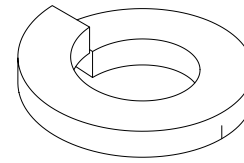

M8 SPRING LOCK WASHER
QTY-40

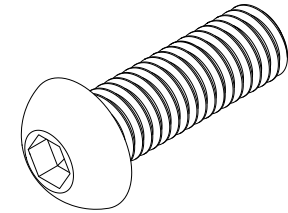

M8-25 BUTTON HEAD SCREW
QTY-32

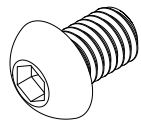

M6-12 BUTTON HEAD SCREW
QTY-6

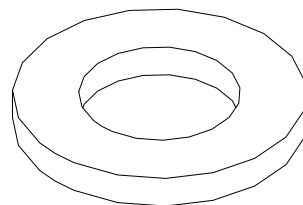

M10 WASHER
QTY-12

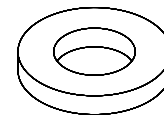

M6 FLAT WASHER
QTY-6

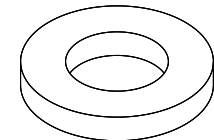

M8 FLAT WASHER
QTY-40

INSTALL

STEP 01

1.1 SLIDE HALF OF THE RAIL NUTS INTO THE PASSENGER SIDE FACTORY ROOF RAIL, AND HALF OF THEM INTO THE DRIVER SIDE RAIL.

1.2 SPACE OUT THE RAIL NUTS CLOSE TO THE FINAL POSITION

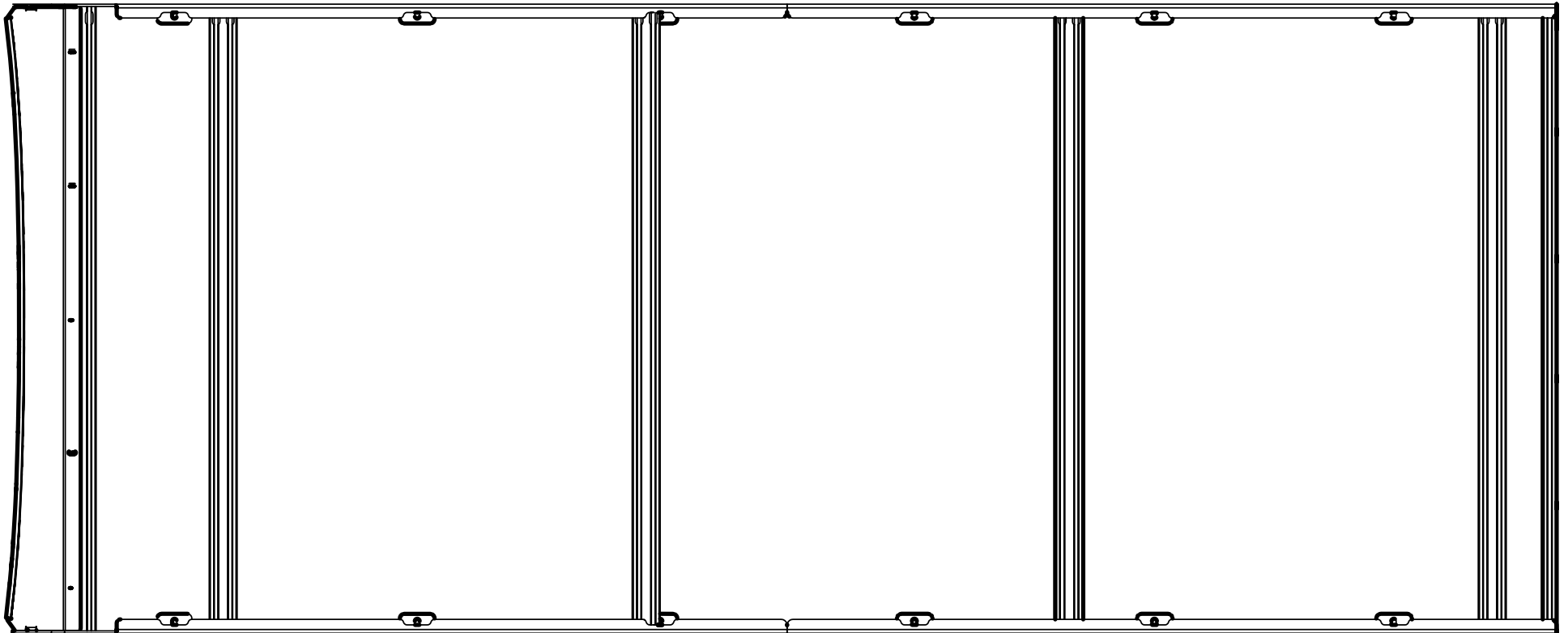

STEP 02

2.1 START LOOSELY ATTACHING THE SIDE RAILS TO THE ROOF RAILS

2.2 USING THE M10-22 HEXAGON HEAD SCREW, M10 SPRING LOCK WASHERS & M10 WASHERS, LIGHTLY TIGHTEN THEM DOWN LEAVE ABOUT AN EIGHTH OF AN INCH GAP SO YOU CAN ADJUST IT BEFORE TIGHTENING IT DOWN LATER.
(SEE FIGURE 3 FOR DETAIL)

2.3 USING THE M8-20 BUTTONHEAD SCREWS, M8 WASHERS, M8 NYLOCK NUTS AND THE JOINT PLATE YOU CAN ATTACH THE SIDE RAILS TOGETHER AS SEEN IN FIGURE 4

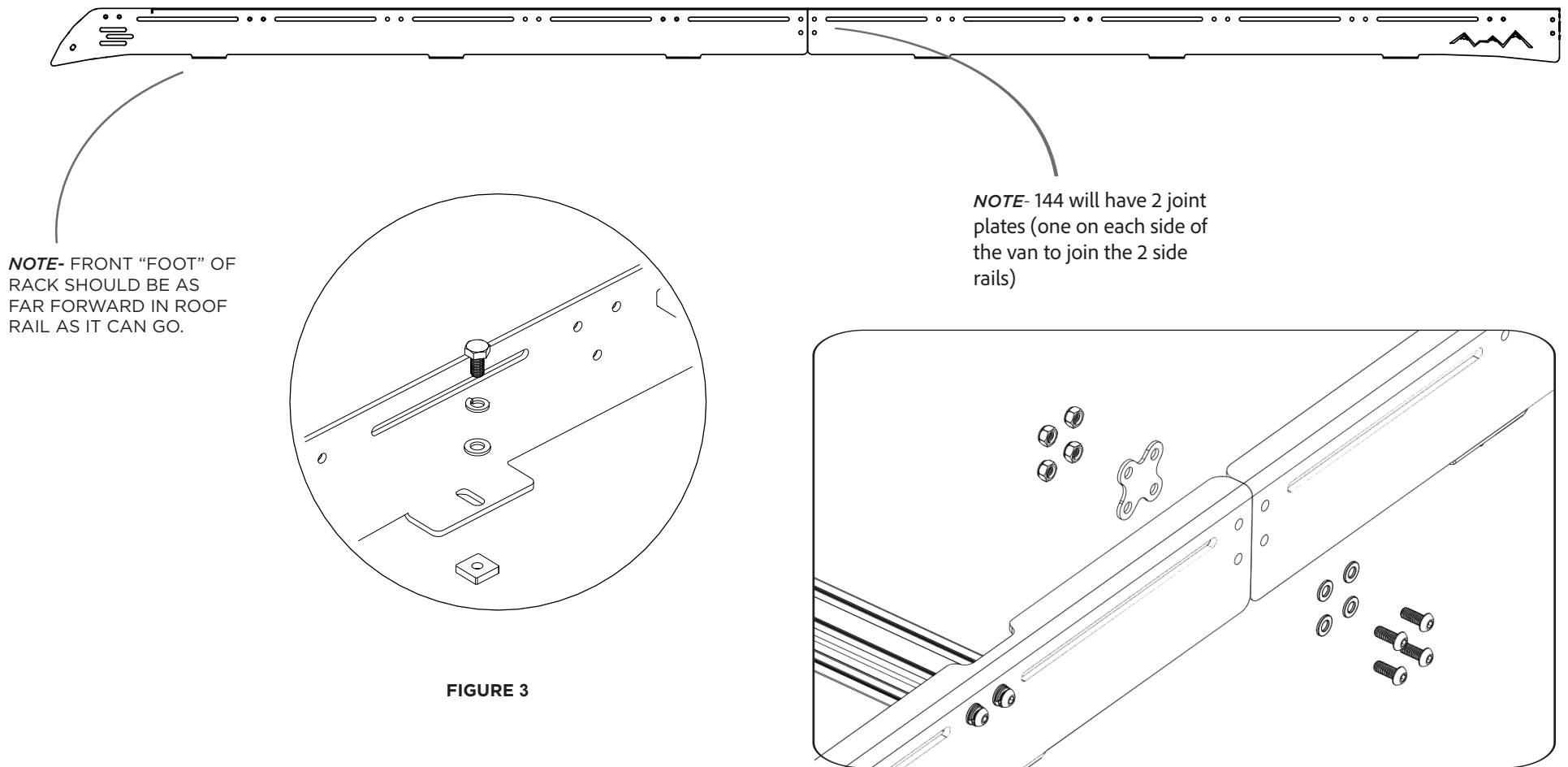

STEP 03

3.1 PLACE YOUR CROSSBARS IN THE DESIRED LOCATION, LOOSELY BOLTING THE M8-25 BUTTON HEAD SCREWS, M8 SPRING LOCK WASHERS & M8 WASHERS IN PLACE.

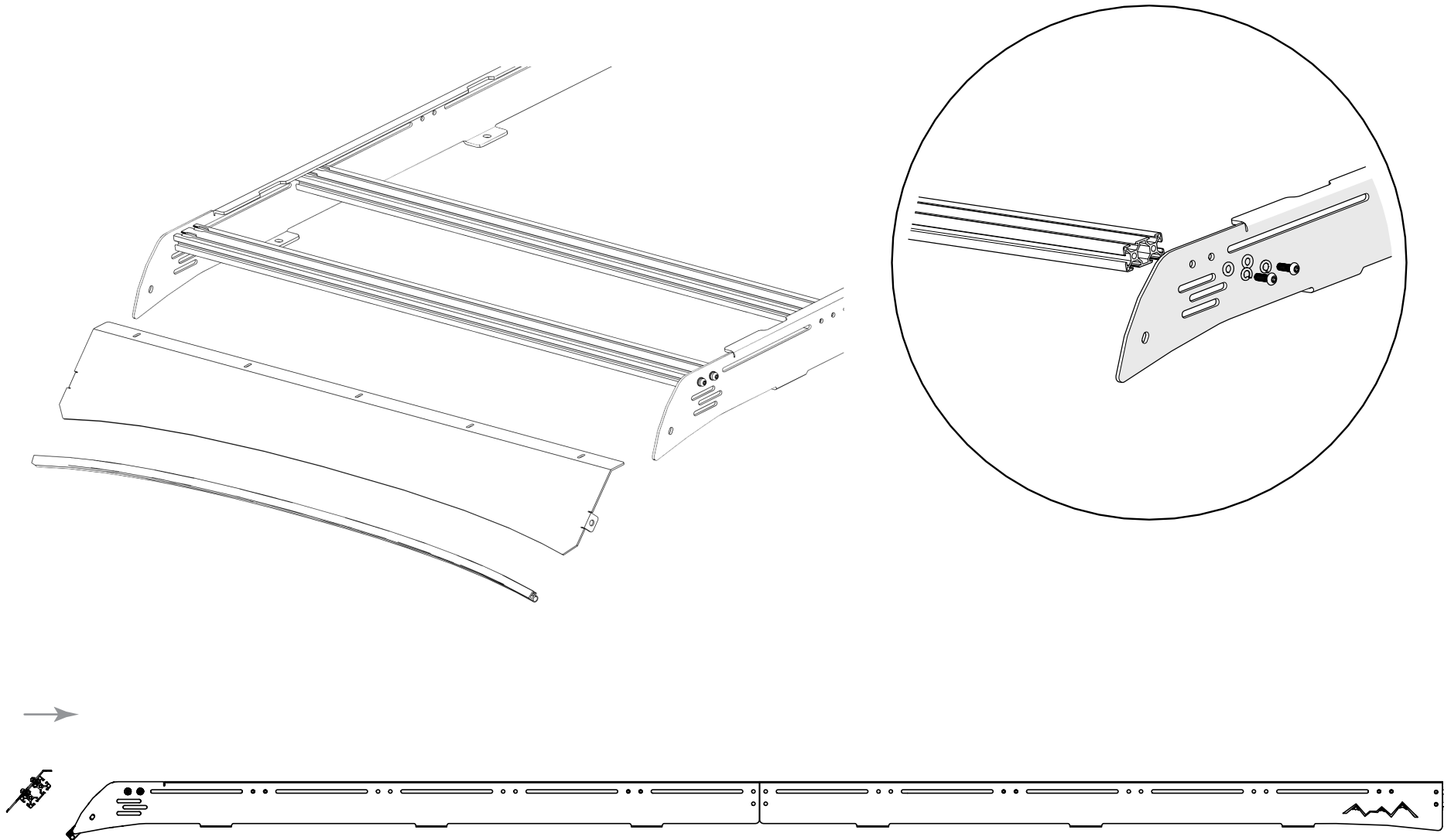

STEP 04 STANDARD FAIRING OR FAIRING FOR LIGHT BAR

4.1 INSTALL THE FAIRING ON CROSSBAR WITH M6 BUTTON HEAD SCREW, M6 FLAT WASHER AND THE RAIL NUTS. *TIP, INSTALL THE HARDWARE LOOSELY THROUGH THE FAIRING AND SLIDE THE CROSS BAR TO ATTACH THE TWO. ONCE CENTERED, TIGHTEN DOWN THE M6-12MM BUTTON HEADS TO LOCK THE FAIRING TO THE CROSSBAR.

4.2 PLACE THE FAIRING WITH THE CROSSBAR IN THE CORRECT LOCATION OF THE SIDE RAIL, BOLTING THE M8-25 BUTTON HEAD SCREWS & M8 WASHERS IN PLACE.

4.3 IF UTILIZING THE FAIRING FOR THE LIGHT BAR REFER TO THE LIGHT BAR MANUFACTURERS MOUNTING INSTRUCTIONS, SEVERAL M6 OR M8 RAIL NUTS MAY BE REQUIRED AND A SPECIFIC SCREW LENGTH TO ACCOMMODATE THE MANUFACTURERS BRACKET BASE. PLACE THE RAIL NUTS IN THE CROSSBAR TRACK TO ALIGN WITH THE LIGHT BAR BRACKETS AND TIGHTEN IN DESIRED LOCATION, ADDITIONAL HARDWARE MAY BE NEEDED TO ATTACH THE LIGHTBAR.

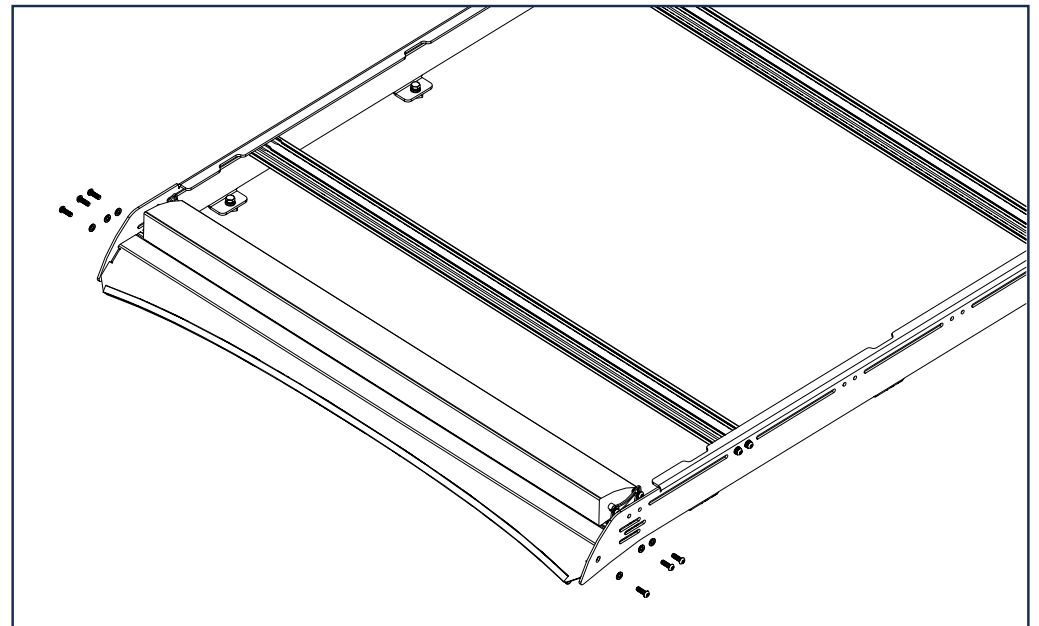
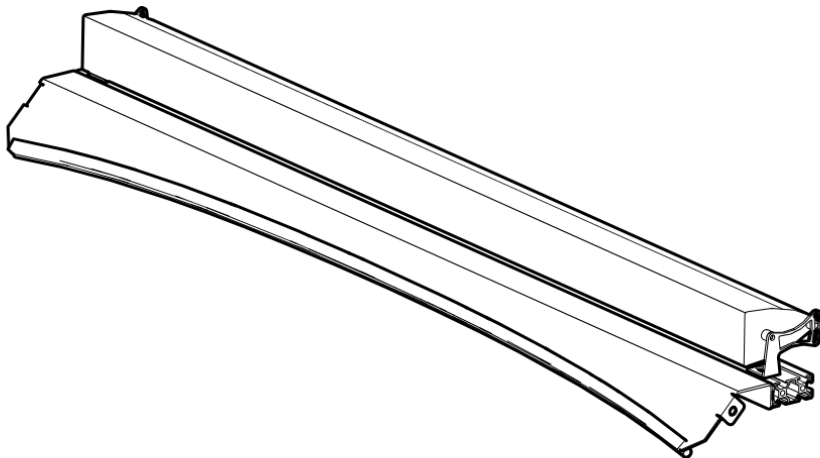
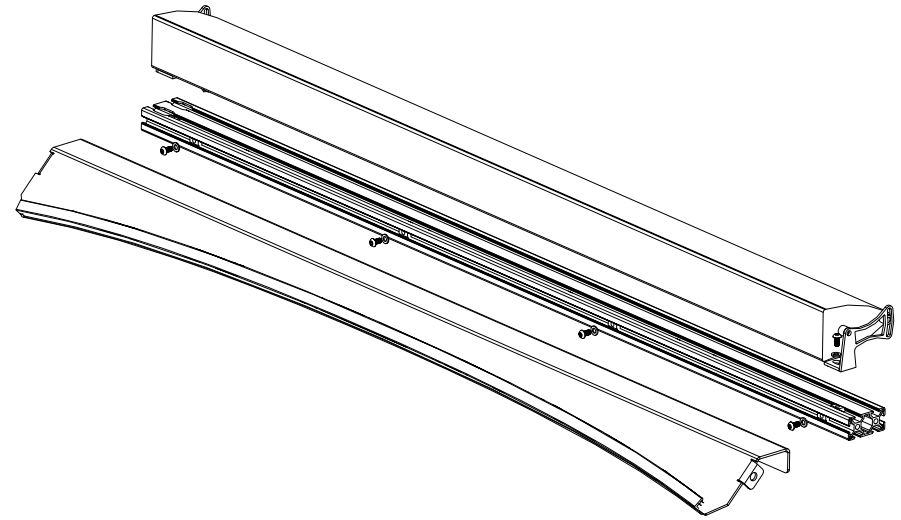

STEP 5

5.1 TIGHTEN ALL CROSSBAR BOLTS USING THE 5 mm ALLEN WRENCH

5.2 ONCE YOU HAVE DETERMINED THE RACK IS IN THE DESIRED LOCATION AND ALL CROSS BARS HAVE BEEN SECURED, MOVE ON TO ALIGNING THE SIDE RAILS AND TIGHTENING THE JOINT PLATES. FINALLY TIGHTEN THE SIDE RAILS TO THE VANS ROOF RAILS.

NOTE- DO NOT OVERTIGHTEN! IF YOU ARE CONCERNED ABOUT THE BOLTS BACKING OUT, YOU CAN PUT A DAB OF BLUE LOCTITE ON THE BOLTS BEFORE TIGHTENING DOWN COMPLETELY.

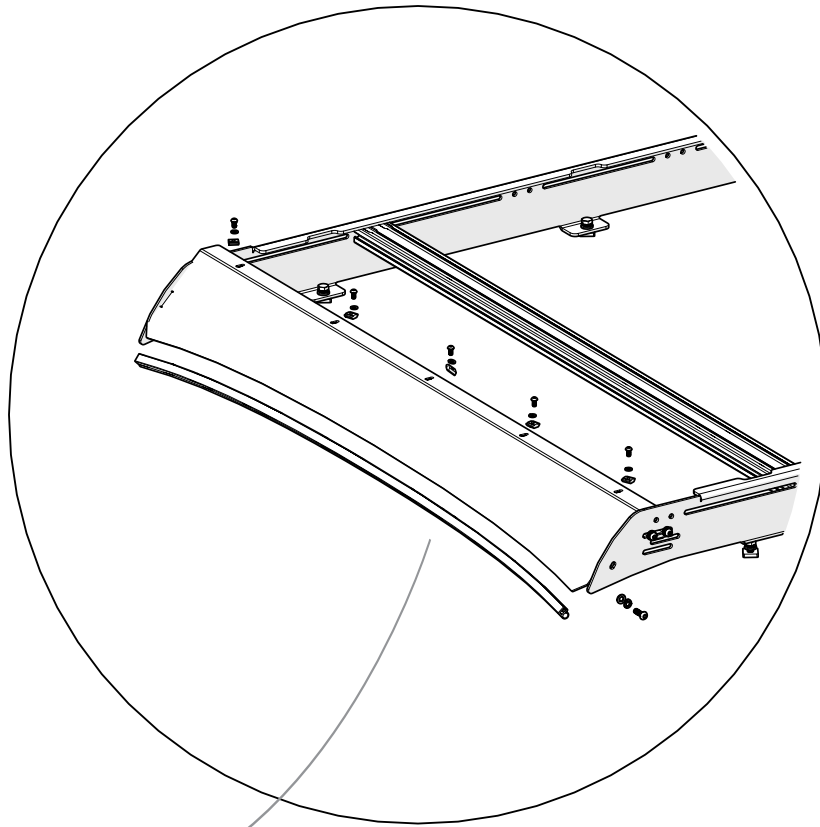

STEP04

STANDARD FAIRING INSTALLATION
WITH TRIM ATTACHED ON THE
BOTTOM EDGE

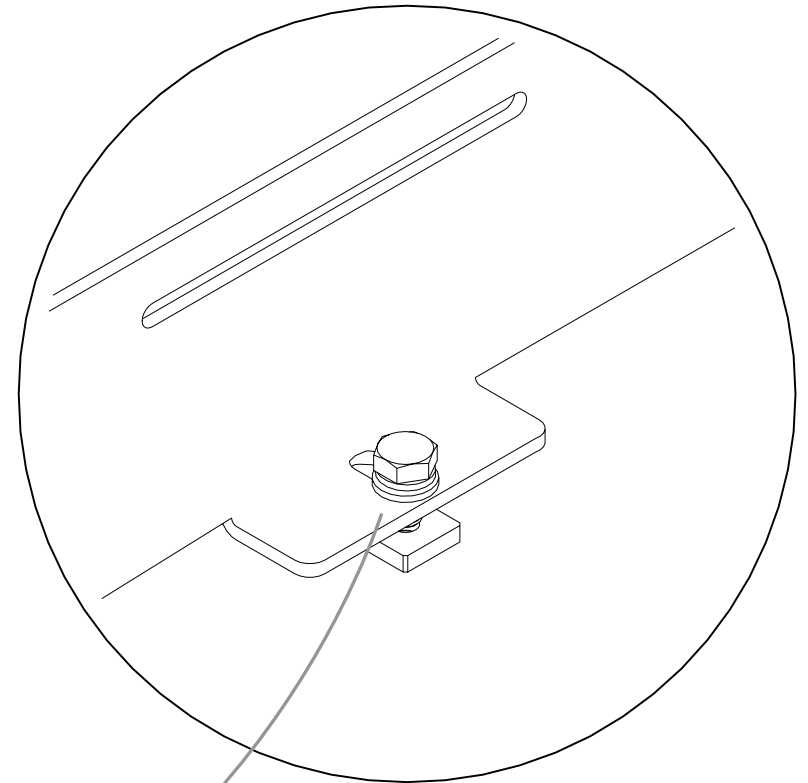

STEP05.2

NOW TIGHTEN SIDE RAILS TO ROOF RAIL USING THE 17 mm WRENCH

GET THERE WITH WHITE TOP ADVENTURES



thanks!



info@whitetopadventures.com